

Application of lifting magnets in industrial use are found in material handling of ferrous objects (sheets, plates, blocks & pipes) and their clamping, hoisting, and lifting.

LIFTON MAGNETS has a wide range of lifting magnets for these purposes. In addition to permanent magnet systems, LIFTON also has a wide range of electro & electro-permanent magnet systems equipped with radio remote control.

All LIFTON lifting magnets are simple to operate and almost maintenance free. High quality and durable materials are used for manufacture of these lifters.

Latest in the series of LIFTON LIFTERS are the Neodymium (NdFeB) permanent magnet based NeoLifters.

IMPORTANT POINTS TO NOTE

In spite of the excellent properties of LIFTON Lifters, when working with the permanent magnet range a few points must be noted.

THICKNESS OF WORKPIECE

Holding power is optimal for materials of thickness 30mm or more.

SURFACE CONDITION OF THE WORKPIECE

There is a reduction in the lifting capacity when the surface of the material is painted or coated as the pole plate cannot come in direct contact with the ferrous surface. This distance is called the air-gap. The air-gap size determines the lifting capacity.

SAFETY FACTOR

LIFTON strictly adheres to a safety factor of 3:1 for all lifting magnets.

PROPERTIES AND DIRECTIONS OF USE

While the surface condition i.e the area of contact is very important, in general; a smooth flat surface is good enough. The magnet should always be hung from the centre of the job i.e. used in equilibrium as far as possible.

A magnet can lift 1000 Kgs of Solid Steel Plate provided the plate is more than 30 mm thick and the maximum size is 2000 x 2000 mm. A Magnet can lift 100% at plate > 30 mm thick and



will lift only 60% when the thickness is 25 mm. So the magnet capacity is to be de-rated depending upon the thickness of plate to be handled. If the thickness is less, the magnetic induction in steel is lesser, so the lifting capacity is reduced.

The overhanging of the plate from the Magnet should not be more than 1000 mm in any case provided the plate is more than 25 mm thick and does not bend when lifted by the Magnet.

If the thickness is less and the length is more than 2000 mm, then, instead of a single high capacity magnet, more than one magnet of lower capacity is used, making sure that the overhanging on width is not more than 800 mm and length 1000 mm. For Example if you have to lift a plate of say 6000 x 2000 x 12 mm thick, you need to hang atleast 4 Sets of magnets (Each set consist of 2 Nos. magnet, side ways) and they are hanged from a spreader beam of 4000 mm x 1000 mm.

For handling plates of larger sizes, we recommend Telescopic Plate Handling System which is basically a spreader beam having 2 sets of fixed magnets and 2 set of magnets moving between 800 to 1100 mm each side. The magnets are hanged by Spring suspension box with loose chain so that it takes care of the bend of the plates available in market.

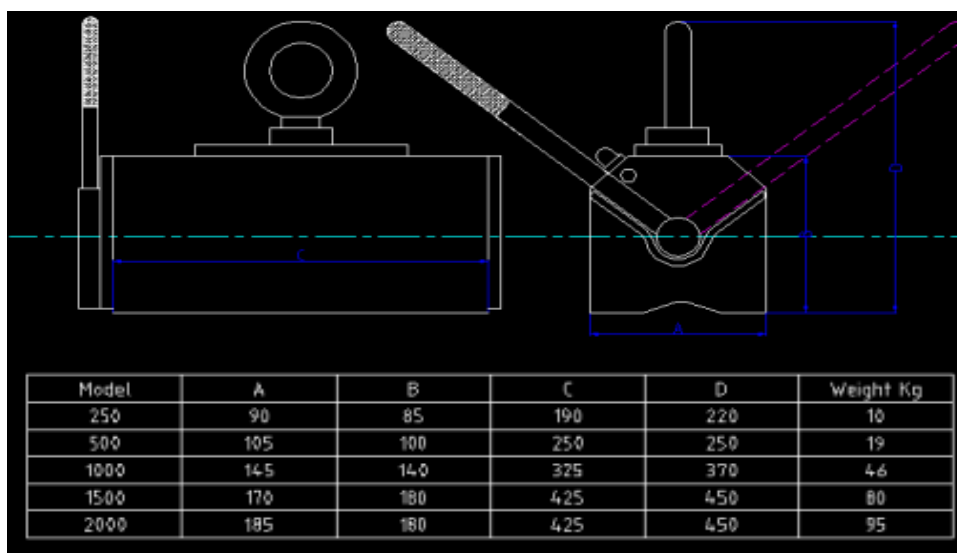

LIFTON NEOLIFTER SERIES

Data Sheet



Model	Dimensions L x W (mm)	Lifter Dead Weight (kgs)	Lifting Capacity Flat Load (kgs)	Lifting Capacity Round Load (kgs)	Tested Lift Flat Load (kgs)	Job Dimensions	
						Flat (Area)	Round (Dia)
NML-S100	135 x 70	4	100	45	300	1200x800	40 - 100
NML-S200	175 x 70	6	200	90	600	1200x800	40 - 100
NML-S300	195 x 90	9	300	125	900	2000x1200	40 - 160
NML-S500	255 x 100	18	500	225	1500	2500x1500	40 - 200
NML-S1000	355 x 142	43	1000	450	3000	3000x2000	60 - 350
NML-S2000	445 x 182	88	2000	900	6000	3500x2000	80 - 400
NML-S3000	470 x 260	175	3000	1350	9000	4000x3000	80 - 400
NML-S5000	550 X 370	350	5000	2250	15000	5000X4000	100-500

Thickness		Rated Capacity (Safe Lifting Weight or SWL)							
	(mm)	5000 Kg	3000 Kg	2000 Kg	1000 Kg	500 Kg	300 Kg	200 Kg	100 Kg
T1	70	100%	100%	100%	100%	100%	100%	100%	100%
T2	60	90%							
T3	50	85%	90%	90%	90%	90%	100%	100%	100%
T4	45	80%	85%						
T5	40	70%	80%	85%	85%	90%	100%	100%	100%
T6	35	60%	70%	75%					
T7	30	50%	60%	65%	80%	80%	90%	100%	100%
T8	25	40%	50%	55%	70%				
T9	20	30%	40%	45%	60%	75%	90%	100%	100%
T10	15	20%	30%	35%	50%	60%			
T11	10	10%	20%	25%	35%	45%	50%	70%	70%
T12	5	5%	10%	15%	20%	25%	30%	40%	40%

- Constructed Using Neodymium Rare earth Magnet - Tremendous lifting capacity & permanence
- State of the art two pole design
- Increased air-gap capability
- Easy ON/OFF for switching. Autolocks when ON
- Extremely compact. Low dead weight.
- Robust. Low maintenance. Attractive design



CAUTION : The maximum rated lift is based upon lifting clean, smooth, flat, low-carbon steel plate, 50mm or thicker, with the full area of the magnet's lifting surface in contact with the load. De-rating is required for round jobs, rusted jobs or alloy steels.

www.liftonmagnets.com

Phone: 65-65599111

Fax: 65-67473561

Email: info@liftonmagnets.com

Works : Blk 3023, Ubi Rd 3, #03-01

Singapore : 408663